

Point of use for speciality gas

Instruction manual

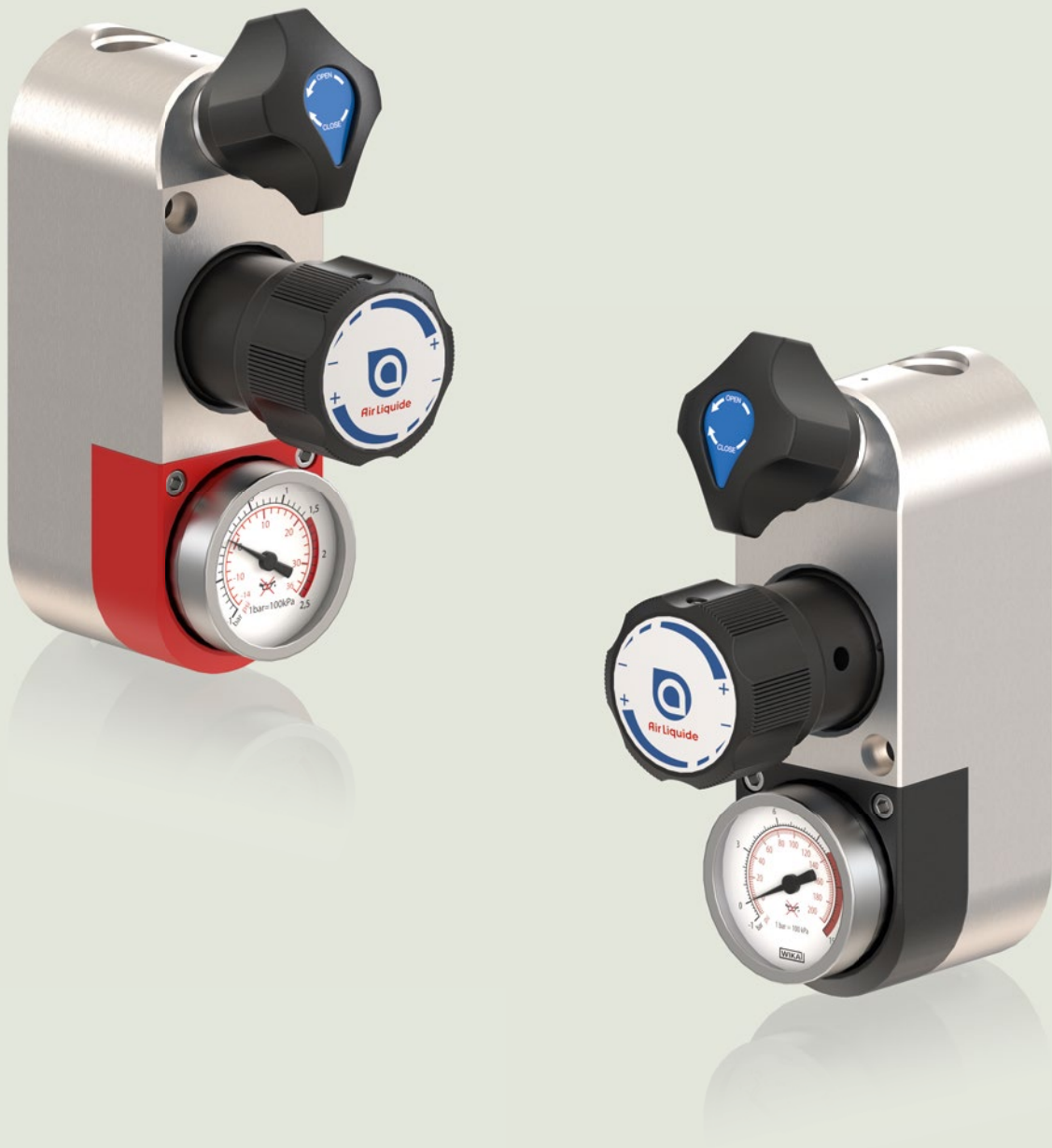

Point of use for speciality gas

Content

Page

1	Preliminary notes	4
1.1	AIR LIQUIDE Commitments	4
1.2	Cleaning	4
1.3	Warranty	4
2	Field of usage	5
2.1	Functions	5
2.2	Intended Use	5
3	Assembly – Activation	6
3.1	Safety	6
3.2	Precautions before assembly	6
3.3	Assembly on pipe	6
3.4	Commissioning/Decommissioning	8
4	Marking	9
4.1	Type plate	9
4.2	CE marking	9
5	Maintenance	9
5.1	Faults – Remedies	9
5.2	Maintenance	9
5.3	Disposal and recycling	9
6	Appendix	10
6.1	Dimensions	10
6.1.1	PDG B / PDG B.S / PDG D / PDG D.S / PDG D FOOD / PDG D.S Pharma	10
6.1.2	VPM / VPM.S	12
6.2	Gas compatibility	13

PDG B / PDG B.S
 PDG D / PDG D.S
 PDG D FOOD
 PDG D.S Pharma

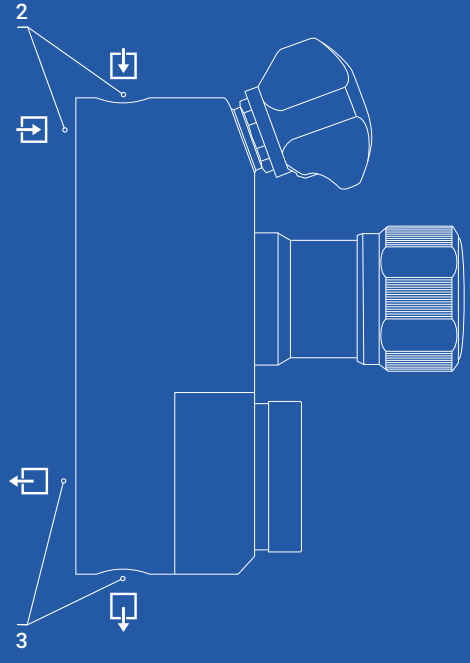
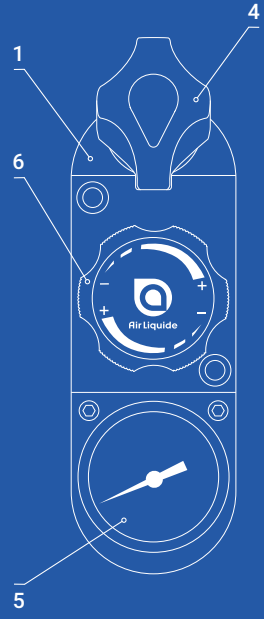

VPM / VPM.S

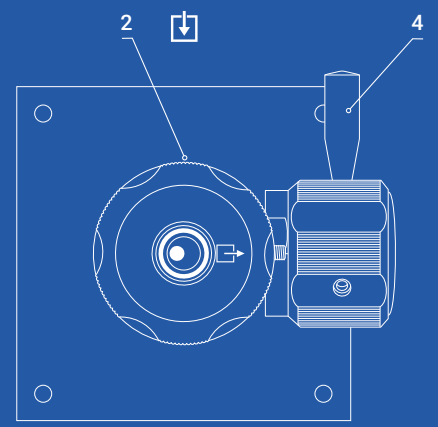
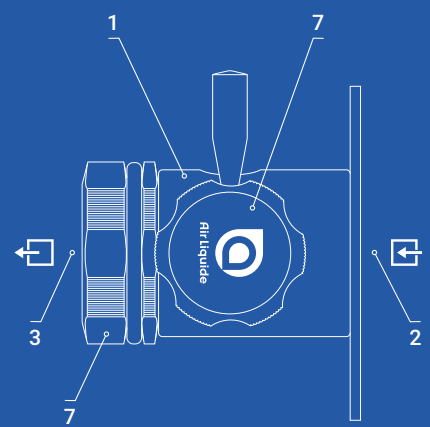

- 1. Regulator body
- 2. Inlet
- 3. Outlet
- 4. Shut-off valve

- 5. Downstream pressure gauge
- 6. Handwheel for regulator
- 7. Handwheel for assembly

1 Preliminary notes

According to the legislator, the operator is responsible for the safety and health of his employees. He must also provide employees with the necessary work equipment to prevent hazards from arising. In addition, must regularly monitor and document the safety-related systems document this.

This operating manual is intended to help that a small part of these requirements can be met.

Our pressure control panels comply with the actual rules of regulation and are design according to the state of the art.

1.1 AIR LIQUIDE Commitments

1.1.1 Conformity

AIR LIQUIDE certifies that the equipment is manufactured, tested and controlled, in accordance with state of the art and AIR LIQUIDE rules.

It is the responsibility of the end user to ensure that such equipment is installed and used in accordance with the current regulations

1.1.2 PED Directive 2014/68/EC: Pressurized equipment

Technical requirements of Article 4 § 3 indicates that Pressure equipment and assemblies below or equal to the limits set out in points (a), (b) and (c) of paragraph 1 and in paragraph 2 respectively shall be designed and manufactured in accordance with the sound engineering practice of a Member State in order to ensure safe use.

Without prejudice to other applicable Union harmonisation legislation providing for its affixing, such equipment or assemblies shall not bear the CE marking referred to in Article 18. By design, these equipment may integrate pressure relief valves or burst disks. In this case, those ones shall neither be CE marked according to paragraph 2 of annex II. In all other cases, pressure relief valves and burst disks shall be CE marked.

1.1.3 ATEX Directive 2014/34/EC

The equipment is not in the scope defined in points a), b) et c) of the article of the ATEX Directive: consequently, they shall not wear the CE marking.

The equipment is not capable of causing an explosion through their own potential sources of ignition: then, they can be installed in ATEX zone 1 or 2, as far as respecting up to date regulations, rules, operating instructions, in accordance with the sound engineering practice are followed during installation and use.

Reminder: it belongs to the end user to define the ATEX zone.

1.1.4 REACH regulation (EC) n°1907/2006

The pressure reducers are made of brass parts, essentially the body, which is a copper alloy with a lead content between 1% and 4% w/w.

As requested by art. 33 of REACH Regulation (Registration, Evaluation and Authorisation of Chemicals) and with reference to current list of SVHC (substances of very high concern) available on ECHA website, we inform that lead may be

present in a concentration above 0,1% w/w in our products made of brass.

Lead inclusion in the SVHC list in June 2018 does not modify the use conditions described in operating instructions.

Lead will not be released to the surrounding environment or the gas used during normal use.

After product end of life, the pressure reducers must be scrapped by an authorized metal recycler.

1.1.5 FOOD regulation (EC) n°1935/2004

The AL equipment enhancing the term "FOOD" in their designation are specifically designed for use with food gases used for food and beverage applications. They are compliant with Regulation EC 1935/2004 which requires that packaging and articles intended to be in contact with foodstuffs are to be manufactured in compliance with good manufacturing practices and standard operating procedures.

Thus, under normal or foreseeable conditions of use, no transfer of contaminants, eg, metal elements, to food in quantities that could endanger human health, modify food composition or deteriorate organoleptic characteristics is expected.

Nevertheless, the end-user must check the compliance with an eventual national regulation.

Articles for food usage has a Food logo marking.

For traceability purposes, the batch number is written on each article and AL can perform a batch recall, as requested by its Quality management system.

1.2 Cleaning

Each equipment is subject to a grease removal and a high quality cleaning to preserve the purity of gas in the equipment as well as for use with oxygen for compatible equipment.

A suitable packaging protects the equipment against exterior pollutants during storage and transport.

Take care to avoid polluting the equipment during installation.

1.3 Warranty

Our "General Terms and Conditions of Sale and Terms of Delivery" apply. These are available to the operator at the latest upon conclusion of the contract. Warranty and liability claims for personal injury and property damage are excluded if they are attributable to one or more of the following causes:

- Improper use of the equipment.
- Improper installation, commissioning, operation and maintenance of the pressure and maintenance of the equipment.
- Operation of the pressure equipment with defective safety devices or improperly installed or or non-functioning safety and protective devices.
- Failure to observe the instructions in the operating manual regarding transport, storage, assembly, commissioning, operation, maintenance and set-up of the pressure equipment.
- Unauthorized structural modifications to the pressure equipment.
- Unauthorized alteration of the cylinder connections for the use of other types of gas, exceeding the permissible inlet

2 Field of usage

pressure permissible inlet pressures, the use of foreign or non-original seals.

- Inadequate monitoring of equipment, screwed connections and sealing parts that are subject to wear.
- Improperly performed repairs.
- Exceeding or falling below the temperature range specified in the data sheet during operation or during storage.
- Catastrophic events due to the effects of foreign bodies and higher force majeure.

The warranty period of this equipment supplied by AIR LIQUIDE is one year, including spare parts and repair, excluding postage and packing costs. Excluded from the warranty are gaskets, these parts are subject to natural wear.

For further information please refer to the General Terms and Conditions of AIR LIQUIDE.

2.1 Functions

The compact point of uses of the PDG product family and the point of uses of the VPM product family in combination with the corresponding pressure or flow regulators enable::

- reduce and regulate the pipe pressure to the desired pressure or flow rate for the downstream applications.
- regulate the outlet pressure or flow and keep it stable.
- ensure the purity of the gas.

2.2 Intended Use

The ALPHAGAZ™ PDG and PDG.S Points of Use are designed for implementation of pure gases and mixtures with purity < N60 thus ALPHAGAZ™ 1 and 2. The ALPHAGAZ™ PDG-A Points of Use are especially designed for implementation of pure acetylene. The VPM/VPM.S point of use can be used in conjunction with the corresponding line pressure regulators for the same area of application. For detailed information, please refer to the gas compatibility table in the appendix.

The PDG product family can be optionally equipped with coloured plastic covers so that the type of gas used can be visually identified on the unit.

Further information on technical details (inlet/outlet pressure, temperature range, etc.), spare parts or other options can be found in the data sheet or the product catalogue. In the appendix you will find, among other things, the gas compatibility table.

3 Assembly – Activation

3.1 Safety

First of all, it is **ESSENTIAL** to read and respect the safety instructions described in the document “General Safety Instructions” delivered with the product.

NEVER dismantle the point of use as long as there is pressure on the pipe or pressure on the regulator.

3.2 Precautions before assembly

After opening the packaging, check that the equipment is not damaged.

- During assembly, it is important to take extreme care to ensure cleanliness and avoid contamination.
- To install the equipment, select a ventilated area, protected from the effects of bad weather.

3.3 Assembly on pipe

3.3.1 PDG product family

- Mount the PDG tap directly on the wall or first on a separate support plate (available), using 2 screws Ø 5mm.
- Make sure that the point of use is firmly connected to the wall to avoid vibration hazards.

- The PDG product family has 2 inlets with an internal thread G3/8” BSPP. One connection is located in the upper area of the rear (for concealed piping), the other directly above the shut-off valve (for exposed piping).
- Select a suitable fitting that fits both the threaded connection of the point of use and the dimension of the connection pipe as well as the material.
- Insert a suitable gasket and screw the selected fitting into the internal thread. Tighten the screw connection with a suitable spanner to 35 Nm.
- Connect the pipeline according to chapter 3.3.3.
- The PDG tapping points have 2 outlets with an internal thread G3/8” BSPP. One connection is located in the lower area of the back (for concealed connection) the other directly below the manometer (for exposed connection). Again, select a suitable fitting or options such as a metering valve or non-return device (outlets also have G3/8” female threads) and proceed as for the installation of the inlet connection.
- Check all connection points for tightness (also the plugs of the unused connections).
- Check whether the connected lines are sufficiently secured against overpressure.

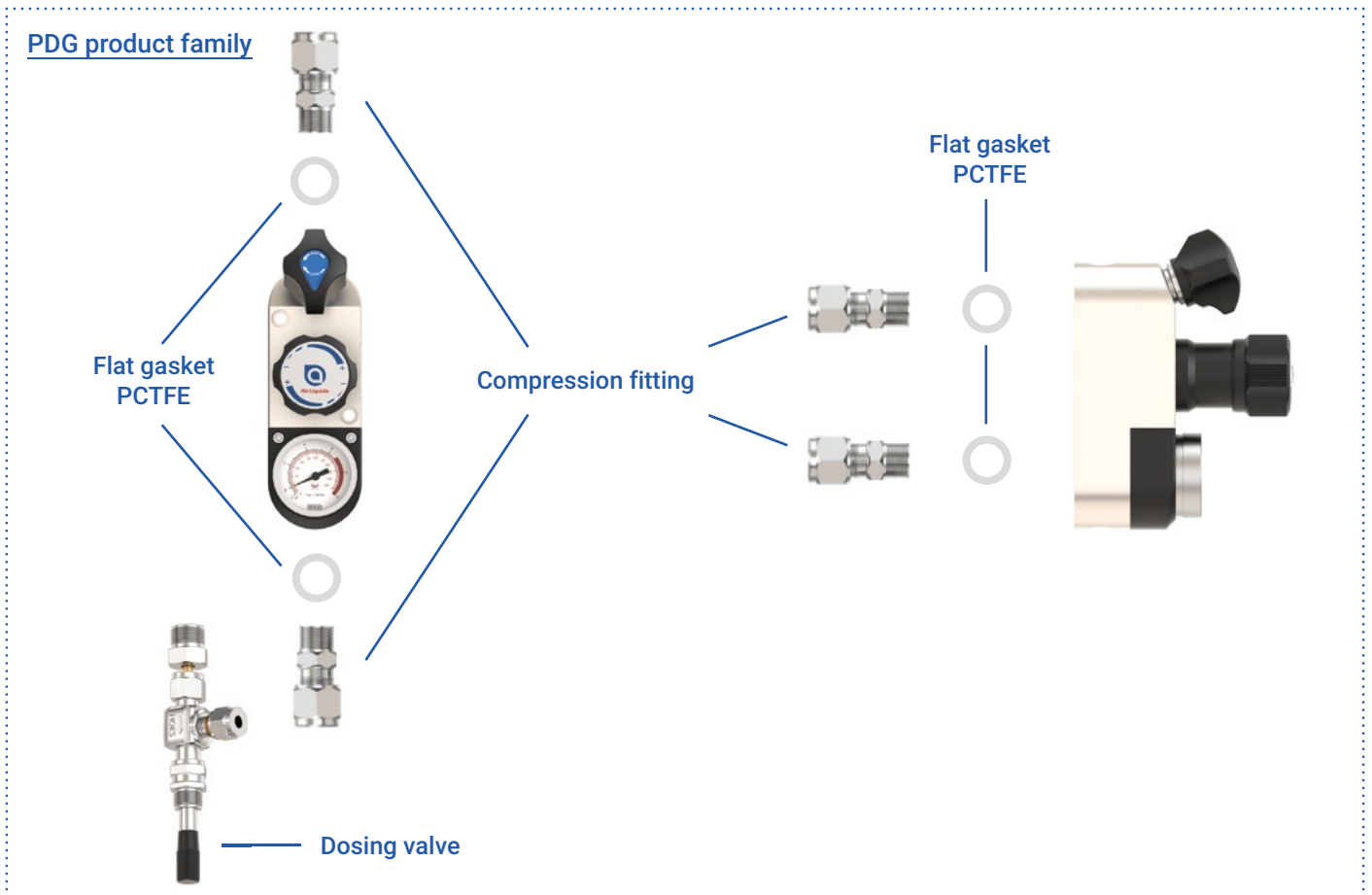

Depending on the type of gas used, the PDG can optionally be equipped with a gas-specific plastic cover.



To do this, the pre-assembled cover must be removed by loosening the hexagon socket screws with a suitable tool and replaced with a cover of your choice

Note: The inlet of the PDG point of use can be realised by rotating it by 180°, also from below. The alignment of the pressure gauge should be adjusted accordingly.

3.3.2 VPM product family

- Mount the VPM point of use to the wall or first on a separate support plate (available), using 4 screws Ø 4mm.
- Make sure that the tapping point is firmly connected to the wall to avoid vibration hazards.

- The VPM product family has an inlet with an internal thread G3/8" BSPP. One connection is located above the shut-off valve (for exposed piping), the other perpendicular to the shut-off valve.
- Select a suitable fitting that fits both the threaded connection of the point of use and the dimension of the connection pipe as well as the material.
- Insert a suitable seal in the inlet of the tapping point and screw the selected fitting into the internal thread. Tighten the screw connection with a suitable spanner to 35 Nm.
- Connect the pipe as described in chapter 3.3.3.
- The VPM tapping points have an outlet with an internal thread G3/8" BSPP. A suitable pressure regulator of choice with an appropriate connection can be mounted here.
- Align the regulator accordingly, fasten it gas-tight via the handwheel (without tools).
- Select a suitable screw connection or options such as a dosing valve or non-return valve for the regulator (outlets also have a G3/8" internal thread) and proceed as with the installation of the inlet connection.
- Check all connection points for tightness (also the plugs of the unused connections).
- Check whether the connected lines are sufficiently secured against overpressure.

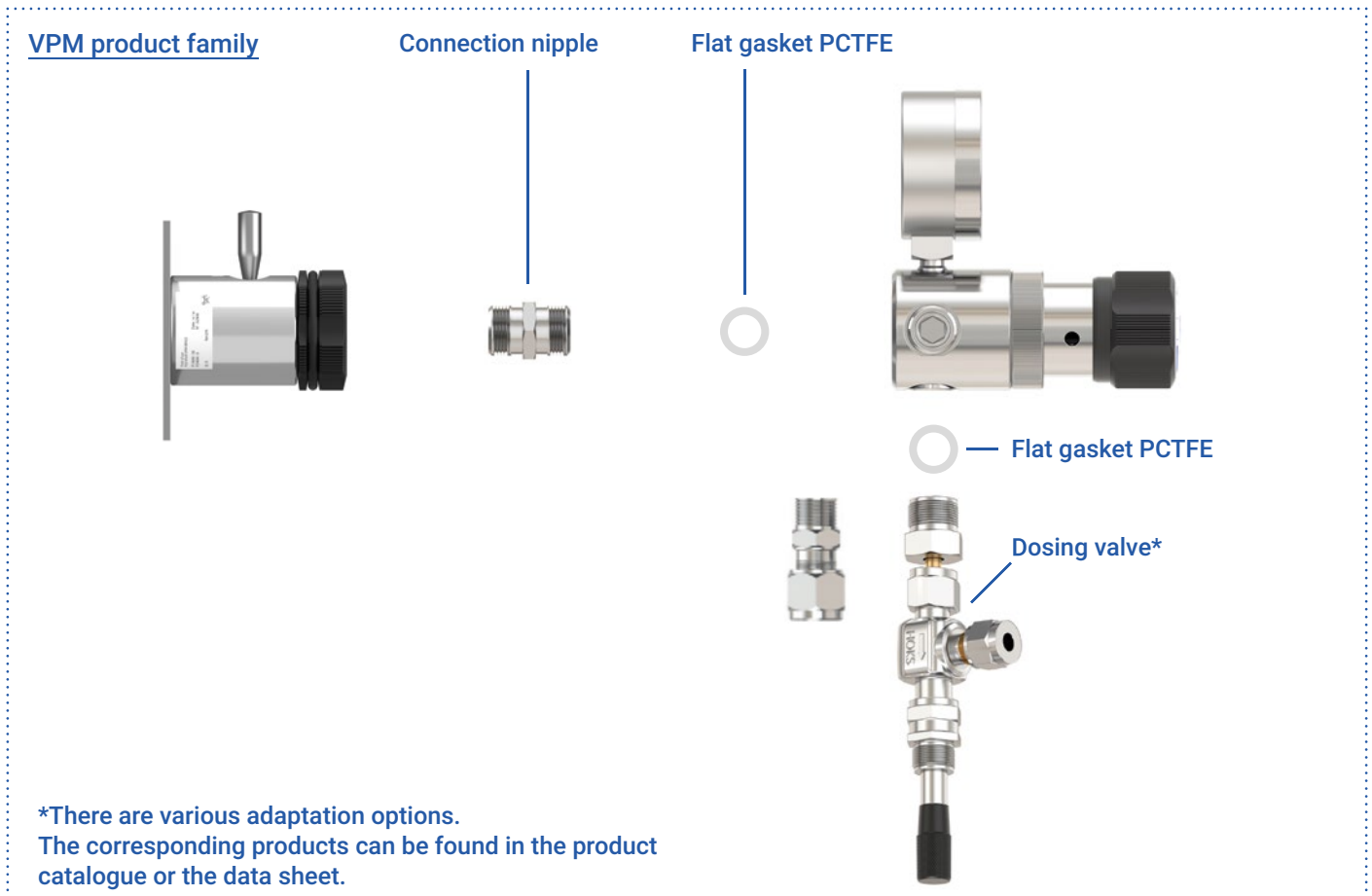

3.3.3 Assembly on pipeline

- Make sure that the tube is cut perpendicular (a good quality tube cutter with a suitable cutting edge is recommended) and deburred. There must be no chamfer at the end of the pipe. Insert the tube inside the connector up to the stop limit on the body. Clamp the nut completely by hand (Fig. 1).

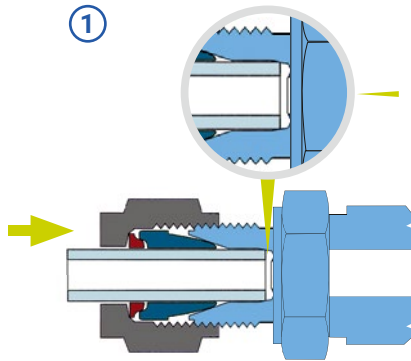

- Hold the fitting body firmly and mark the position of the union nut. Complete the clamping using a wrench by turning the nut a 1/4 turn (Fig. 2). The connection is now correctly mounted.

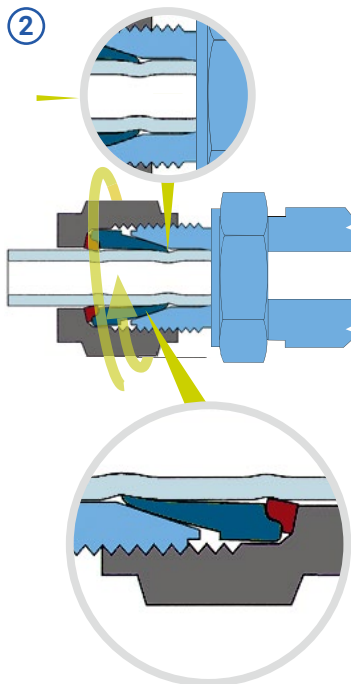

For screw connections up to 4 mm, only one 3/4 turn from the hand-tight position is permissible.

• Instructions for reassembly

Connections can be loosened and retightened several times while maintaining a reliable, leak-free seal.

1. Before loosening the connection, mark the position of the mark the position of the nut in relation to the fitting body.
2. Push the pipe with pre-assembled clamping rings into the body until the pre clamping ring is firmly seated.
3. Tighten the union nut by hand. Then tighten the union with the spanner until you reach the old assembled state position. If you reach this position, you will notice an increased resistance when tightening. Then tighten the union nut lightly with the open-ended spanner. Smaller pipes require less tightening than large ones.

3.4 Commissioning/Decommissioning

3.4.1 Activation

- Make sure that all lines are tightly connected and that the line to the consumer is closed.
- Turn the handwheel of the pressure regulator completely out counterclockwise in a depressurised state.
- Open the shut-off valve of the point of use.
- Set the handwheel of the pressure regulator to the desired outlet pressure by turning it clockwise (indicated on the pressure gauge).
- Slowly open the consumer and establish the desired flow, readjust the pressure if necessary.

3.4.2 Decommissioning

In case of longer interruptions:

- Close the shut-off valve of the point of use.
- Depressurise the point of use completely by removing gas from the consumer until the pressure gauge shows 0 bar and no flow noise can be heard.
- Turn the handwheel of the pressure reducer of the point of use completely out counterclockwise.

4 Marking

4.1 Type plate

On the body of the point of use there is a type plate with information about:

Type designation, date of manufacture, approved upstream pressure (P1), device-specific downstream pressure (P2) and flow rate (Q1). Furthermore, the permissible temperature range and the symbol of oil- and grease-free (for the use of oxygen). The manufacturer's name and a QR code for scanning the operating instructions in the desired language are affixed to the body of the fitting.

4.2 CE marking

As the valve has been designed and manufactured according to "good engineering practice" in accordance with Article 4 (3) of the Pressure Equipment Directive, a CE marking may not be affixed.

5 Maintenance

5.1 Faults – Remedies

Fault	Cause	Remedy
Connection not possible	Wrong connection.	Change the connecting element.
	Connecting element damaged.	
Insufficient gas flow	Passage restricted due to a valve.	Open the necessary valves.
	Gas supply undersized.	Contact Air Liquide.
	Fittings on the consumer do not work.	Change defective fittings.
Gas escape	Leak in the sealing.	Proceed according to chapter 3.6.
Outlet pressure increases	Pressure regulator leaking in the seat.	Take the fitting out of operation.
Unstable outlet pressure and/or ice formation	Flow rate too high.	Flow rate of the pressure reducer note. Limit the flow with the aid of a valve or a suitable orifice plate.
Vibrations	Flow rate too high.	Limit the flow with the help of a valve or a suitable orifice.
	Opening a safety valve in the downstream pressure line.	

5.2 Maintenance

Even though the equipment is reliable, it must be checked periodically. Since this task requires some precautions, it must be done exclusively by a qualified technician. The periodicity of this verification depends essentially on the usage of the equipment (intensive, moderate, occasional). We recommend to replace it every 5 years. In case of an operating accident (insufficient output, leakage, opening of the relief valve or accidental damage): replace the equipment.

- Use only original parts and do not modify the equipment.
- Never dismantle any of the equipment's components.

 **Defective reassembly may cause bursting, malfunctioning and/or an increasing output pressure, which is dangerous for your safety..**

5.3 Disposal and recycling

At the end of the equipment's useful life or when it is impossible to repair it, it is essential to respect the local regulations for recycling/disposal of our equipment. To prevent reuse, these products must be unsuitable for use. In accordance with EU Directive 2018/851 on waste, the owner of the equipment ensures that when recovery is not carried out in accordance with article 10, the waste will be subjected to safe disposal operations that comply with the provisions of article 13 on the protection of human health and the environment. The licensee must take steps to promote high quality recycling and, to this end, must establish separate waste collections when technically, environmentally and economically feasible and adequate to meet the quality standards required by the relevant recycling sectors.



6 Appendix

6.1 Dimensions (mm)

6.1.1 PDG B / PDG B.S / PDG D / PDG D.S / PDG D FOOD / PDG D.S Pharma

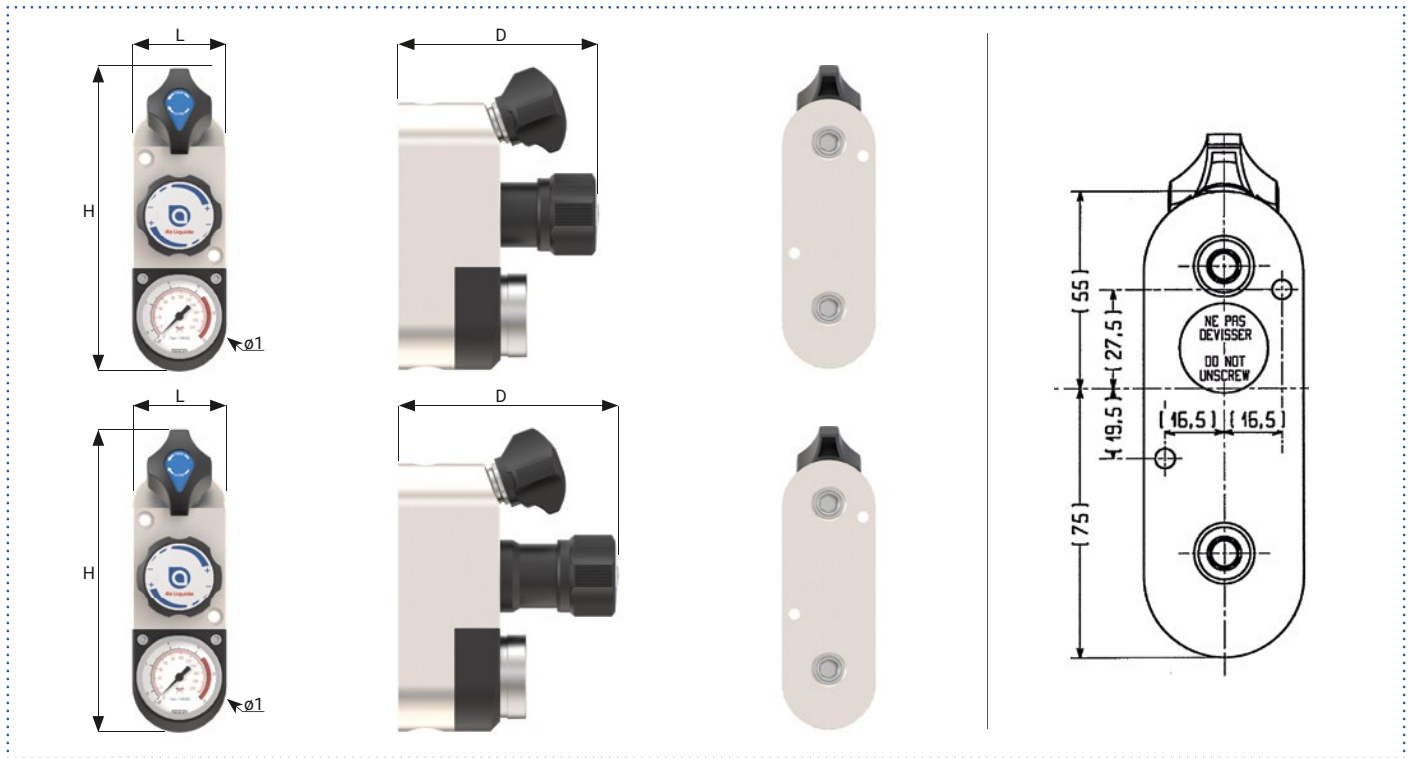

Model	L	H	D	Ø 1
PDG with membrane	45	145	94	40
PDG with bellows	45	145	108	40

1 PDG-B - PDG- A (aluminium)	0,85 kg
40 PDG-D (brass)	2,00 kg
PDG.S - PDG.S Pharma (stainless steel)	1,90 kg

Support plates for point of use PDG

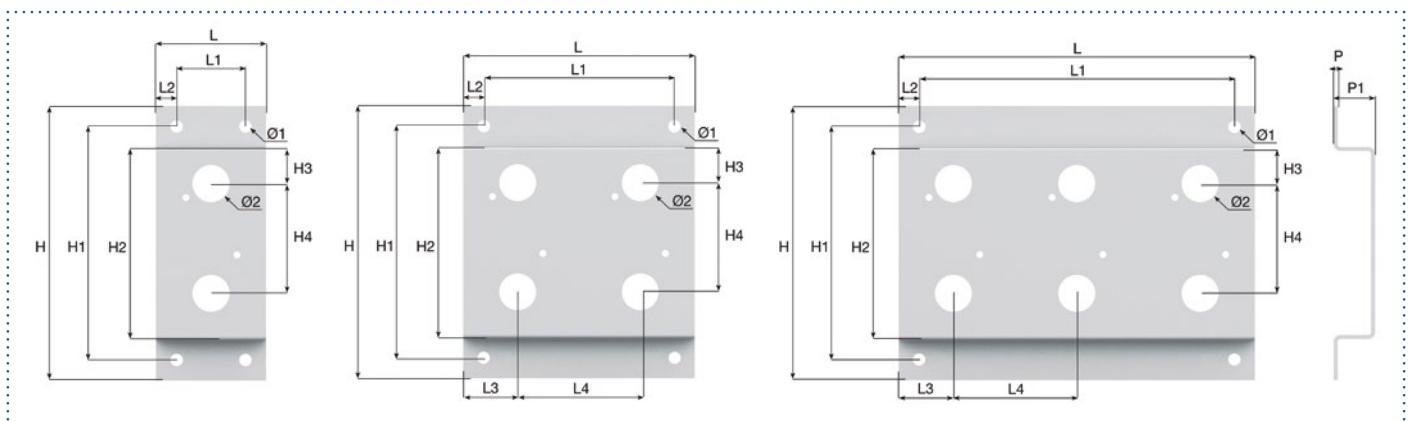

Model	L	L1	L2	L3	L4	H	H1	H2	H3	H4	P	P1	Ø1	Ø2
Support plates for 1 point of use	80	50	15	-	-	200	170	140	26	80	3	30	9	20
Support plates for 2 points of use	160	130	15	40	80	200	170	140	26	80	3	30	9	20
Support plates for 3 points of use	240	210	15	40	80	200	170	140	26	80	3	30	9	20

Support plates for PDG point of use (only for Switzerland)

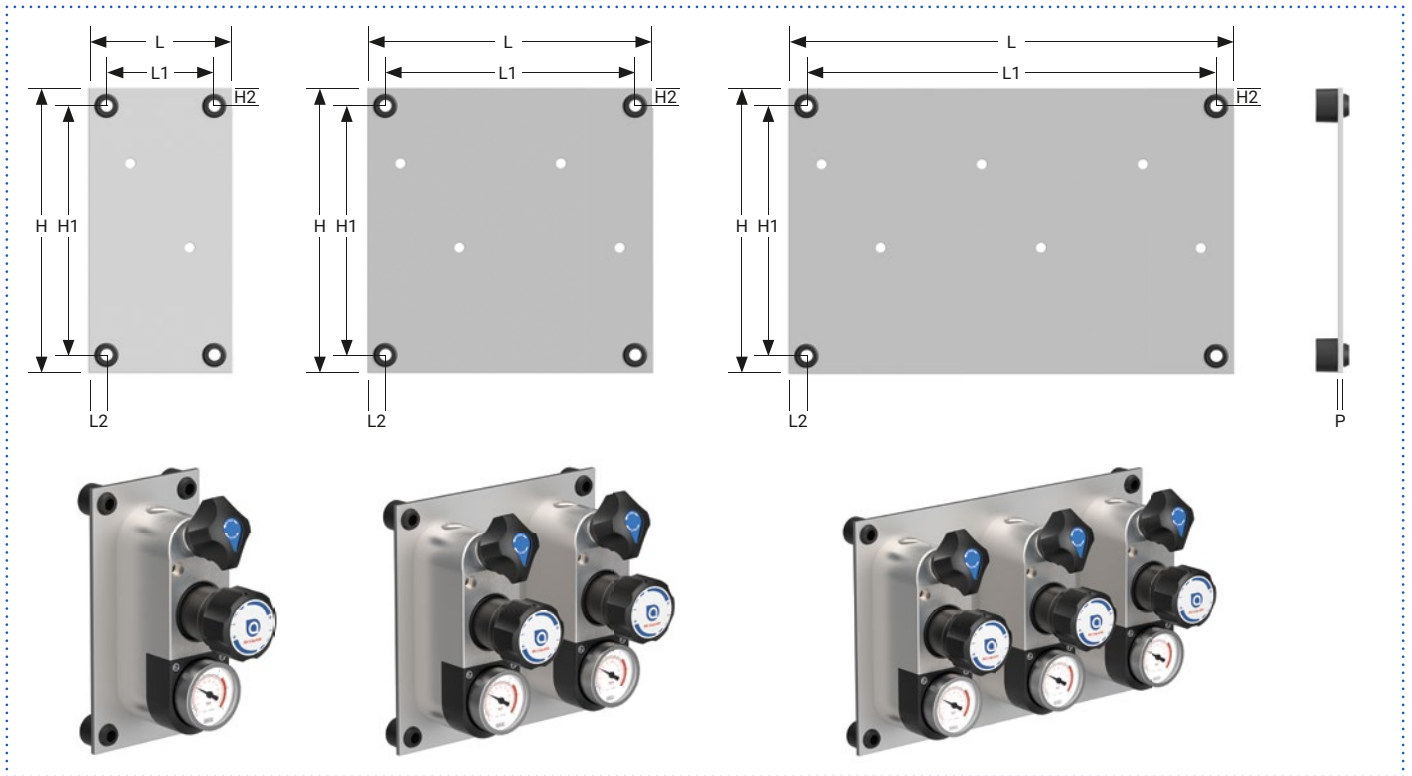

Model	L	L1	L2	H	H1	H2	P
Support plates for 1 point of use	80	60	10	160	140	10	3
Support plates for 2 points of use	160	140	10	160	140	10	3
Support plates for 3 points of use	240	230	10	160	140	10	3

6.1.2 VPM / VPM.S

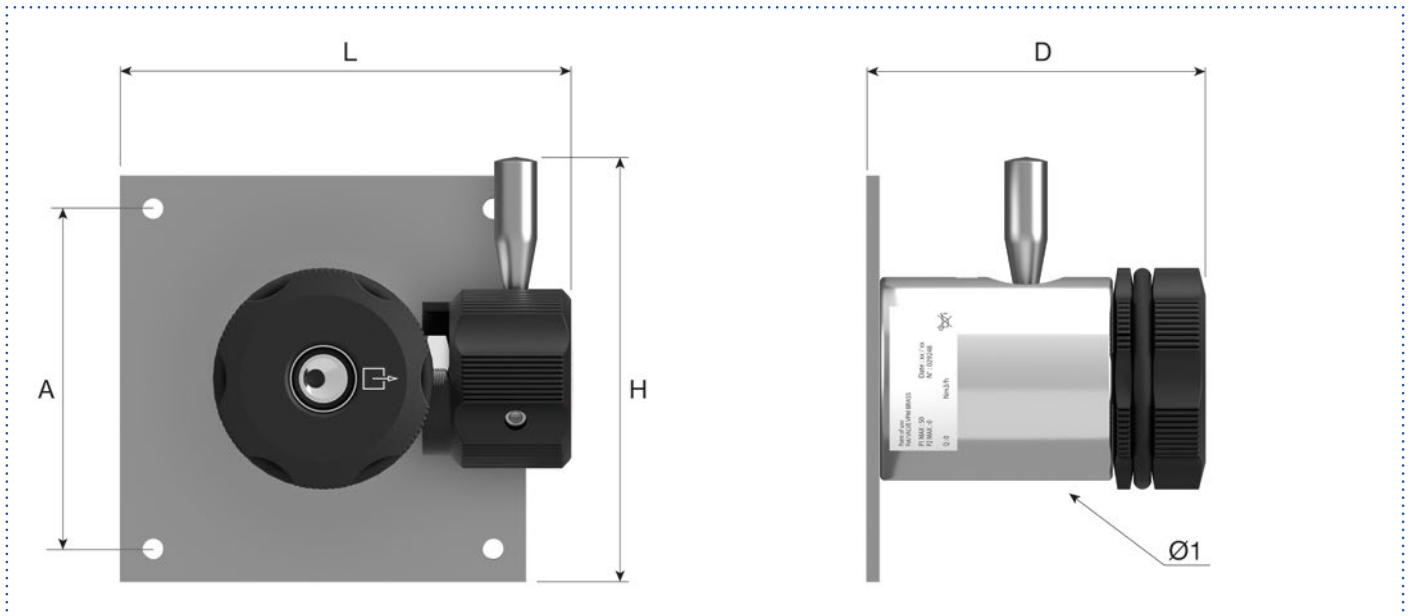

Model	L	H	D	A
VPM	100	95	74	75
VPM.S	100	95	74	75

Support plates for points of use VPM / VPM.S

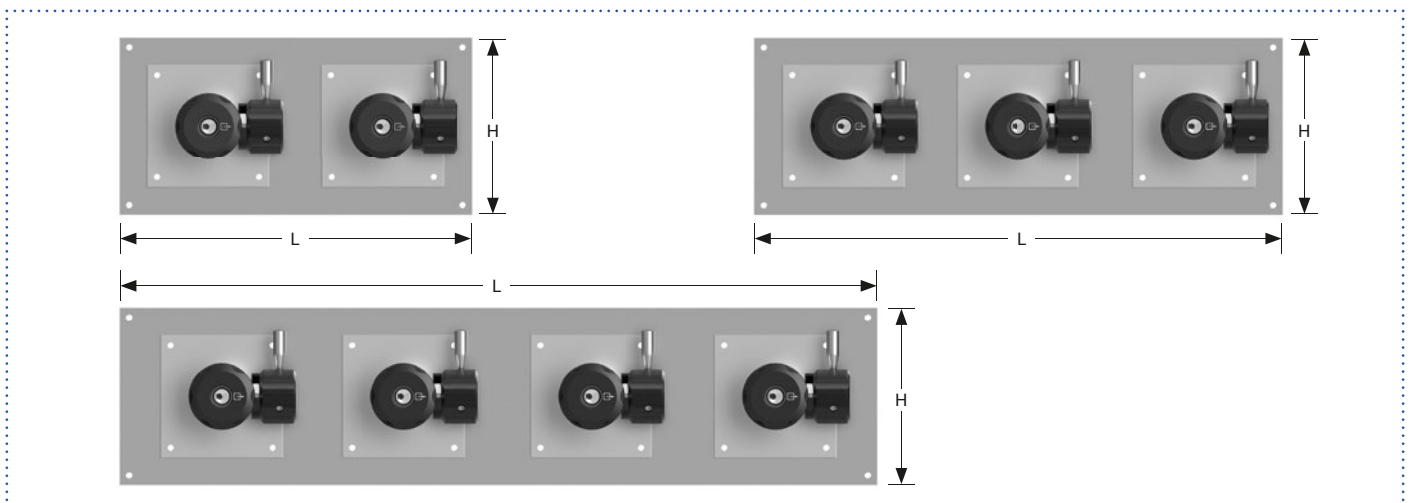

Model	L	H
Support plates for 2 points of use VPM / VPM.S	260 mm	130 mm
Support plates for 3 points of use VPM / VPM.S	390 mm	130 mm
Support plates for 4 points of use VPM / VPM.S	560 mm	130 mm

Contact

Air Liquide Deutschland GmbH

Fütingsweg 34
47805 Krefeld
Tel: +49 (0) 2151 379 - 9444
equipment@airliquide.com
www.airliquide.de

Air Liquide Austria GmbH

Sendnergasse 30
2320 Schwechat
Tel: +43 810 242427
technik.at@airliquide.com
www.airliquide.at

Carbagas AG

Hofgut
3073 Gümligen
Tel: +41 31 95 05050
info@carbagas.ch
www.carbagas.ch

www.airliquide.de



A world leader in gases, technologies and services for Industry and Health, Air Liquide is present in 60 countries with approximately 66,300 employees and serves more than 3.9 million customers and patients.