

Safety valve MG-84/MG-95

User manual

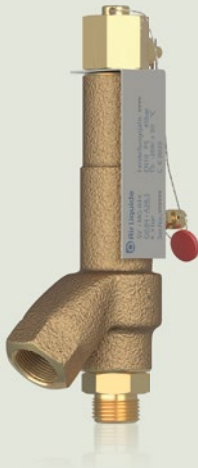
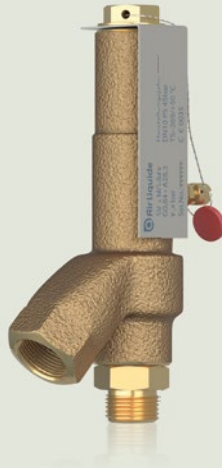

1	Preliminary Notes	3
2	Warranty and liability	3
3.	Intended use	3
3.1	Marking	3
4	Installation	4
4.1	Mounting position	4
4.2	Assembly MG-84 and MG-95	4
4.2.1	Inlet connection for variant MG-84 S/A and MG-95	5
4.2.2	Inlet connection for variant M, K	5
4.2.3	Outlet connection for variant MG-84 and MG-95	6
4.3	Notes on Potential Hazards	7
5	Maintenance and Service	8
5.1	Maintenance	8
5.1.1	Recommended inspection and maintenance intervals	8
5.1.2	Checks	8
5.1.2.1	Application of test pressure	9
5.1.2.2	Checking of seat tightness	9
5.1.2.3	Checking of response pressure	9
5.1.2.4	Checking of opening pressure	9
5.2	Repairs	9
6	Dismantling and disposal	9
6.1	Notes regarding disassembly	9
6.2	Disposal	9

1 Preliminary Notes

According to the law, the operator is responsible for the operational safety and health of his employees. He is obliged to prepare a risk analysis of his company.

He must also provide employees with the necessary work equipment to prevent hazards from occurring. In addition, he must regularly monitor the safety-related systems and system components and also document this.

These operating instructions are intended to help ensure that a small part of these requirements can be met.

2 Warranty and liability

In principle, our "General Terms and Conditions of Sale and Delivery" apply. These are available to the operator at the latest upon conclusion of the contract. Warranty and liability claims for personal injury and property damage are excluded if they are due to one or more of the following causes:

- Improper use of the equipment.
- Improper installation, commissioning, operation and maintenance of the equipment.
- Operating the equipment with defective safety devices or improperly installed or non-functioning safety and protective devices.
- Failure to observe the instructions in the operating manual regarding transport, storage, assembly, commissioning, operation, maintenance and setup of the equipment.
- Unauthorized structural modifications to the equipment.
- Unauthorized modification of the cylinder connections for the use of other types of gas, exceeding the permissible inlet pressures, the use of third-party or non-original seals.
- or non-original seals.
- Inadequate monitoring of equipment, screw connections and sealing parts that are subject to wear.
- Improperly performed repairs.
- Exceeding or falling below the temperature range specified in the data sheet during operation or storage.
- Catastrophic events caused by foreign bodies and force majeure.

3 Intended use

The Type MG-84 and MG-95 safety relief valve is designed to protect vessel and piping systems from impermissible overpressure.

The valve is available in four different versions:

- S = Standard (technical gases up to N48)
- M = MEGAPUR - safety valve for Alphagaz 1 systems
- A = with lifting lever – for systems where a check of the mechanical function of the valve is mandatory
- K = for corrosive gases

Product-specific data, permissible operating conditions and media can be found in the corresponding data sheet.

Deviating operating conditions and areas of application are not permitted or require the approval of the manufacturer.

3.1 Marking

The safety valves are equipped with individual marking for identification. On the valve there is a type plate with information about:

- Manufacturer
- Date of manufacture
- Type designation
- approved temperature range
- release pressure [bar]
- relevant standards
- CE marking
- Pi marking

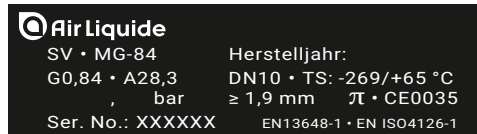

4 Installation

Spring-loaded safety valves must always be installed in an upright position, taking into account the direction of flow. The valves must be mounted in such a way that no persons or property are damaged by the escaping operating medium when they are actuated. To ensure proper functioning, no impermissible static, thermal or dynamic stresses may be transferred to the valve. Reaction forces must be taken into account. No shut-off must be installed between the safety valve and the pressure system. Blow-out lines must not be constricted or have a negative influence on the function and performance of the valve and must discharge without danger. No liquid may collect in the blow-out system, nor may small creatures, especially nest-forming insects, enter. If necessary, a protective screen. Sch-No.: 126835, must be used.

4.1 Mounting position

Always select the installation position so that moisture can flow out of the exhaust port. Otherwise, the installation position is arbitrary for response pressures greater than 4 bar. For pressures below 4 bar, vertical installation is required. Any other installation position changes the set pressure due to the weight forces of the internal parts.

4.2 Assembly MG-84 and MG-95

The valve is delivered ready for installation and is in accordance with the data on the nameplate. The setting elements are secured and sealed. The installation of safety valves presupposes that pressure losses in the supply line and back pressures in the discharge line do not cause any loss of function. The pressure connection is made via a pipe $\varnothing 12 \times 1$ for types MG-84 (only version A, S and P). A progressive ring with union nut is required. For the pre-assembly of the progressive ring, the hardened pre-assembly connecting piece type VOMO 12 L (part no.: 127381) must be used.

 **If not respected, the connection nozzle can be damaged, so that the entire valve cannot be put into operation.**

The assembly depends on the material of the of the pressure-bearing pipeline used:

Pipe	Progressive Ring	Cone	Preassembly VOMO 12 L
Copper	Brass	Brass	optional
austenitic steel	1.457	austenitic steel	mandatory

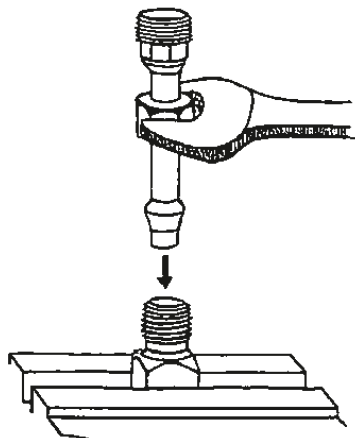

The MG-84 in the special versions M, K are connected to the pressurized line on the inlet side via a VCR connection.

For this purpose, the pipeline must be equipped with the appropriate VCR welding socket plus union nut. The use of lubricants facilitates proper installation. However, no lubricant spray may be used, but only a lubricant approved for oxygen.

Assembly instructions for the ERMETO fitting

Cut the tube vertically, plane the end face, break the edges inside and outside with a max. 0.1 mm chamfer. Apply lubricant on the thread and cone of the fitting as well as the progressive ring and thread of the union nut, but only with lubricant approved by BAM.

Push the union nut and progressive ring over the end of the pipe. Screw on the union nut by hand until contact is felt. Push tube against against the stop in the inner cone of the safety valve inlet connection. Tighten the union nut by approx. 1 1/2 turns. The safety valve must not rotate during this process. A stop edge on the progressive ring limits the tightening.

For the assembly of the safety valves on stainless steel pipes, a pre-assembly of the progressive ring with pre-assembly nozzle, order no. VOMO 12 L

from ERMETO is necessary. This is the only way to ensure the necessary cutting of the progressive ring into the stainless steel pipe..

4.2.1 Inlet connection for variant MG-84 S/A and MG-95

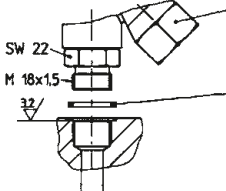
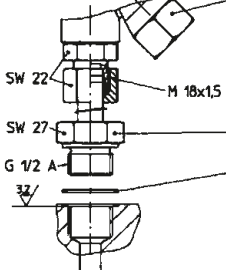
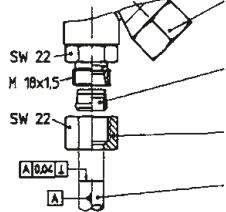
<p>Directly connected with M 18 x 1,5.</p>		<p>Safety Valve</p> <p>Cu-Gasket Ø 18 x Ø 22 x 2</p>	<p>126532</p>
<p>Connected via Adapter</p> <p>Advantage: Free choice of outlet direction.</p>		<p>Safety Valve</p> <p>Complete adapter</p> <p>Cu-Gasket Ø 22 x Ø 26 x 1,3</p>	<p>126821</p> <p>126512</p>
<p>Connection to existing pipe Ø 12 x 1</p> <p>The pipe length must be taken into account, as the reaction forces must be taken into account when blowing off the valve.</p>		<p>Safety valve</p> <p>Progressive ring for - Cu pipe - Stainless steel pipe</p> <p>Union nut M 18 x 1,5</p>	<p>127368</p> <p>127369</p> <p>127378</p>

4.2.2 Inlet connection for variant M, K

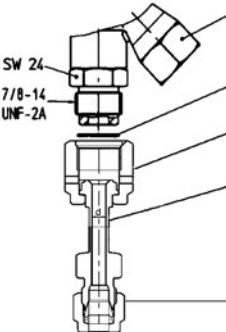
<p>Connected via VCR connection fitting</p> <p>Advantage: Free choice of the direction of the discharge nozzle</p>		<p>Safety valve</p> <p>Gasket</p> <p>VCR union nut</p> <p>Connection fitting</p> <p>Compression fitting 12mm</p>	<p>218119</p>
--	---	--	---------------

** Connectors are standard items from the manufacturer Swagelok

4.2.3 Outlet connection for variant für MG-84 and MG-95



A further discharge line is only necessary if a special discharge of the gas is required.
 Connection of a blow-out line made of copper or stainless steel pipe $\text{Ø } 18 \times 1.5$ with screw connection $\text{G } \frac{1}{2}$ "-18 mm, clear width ≥ 15 mm.

	<p>Blow-out pipe Cu complete (with connection fitting and insect screen)</p>	<p>126849</p>
	<p>Blow-out pipe stainless steel complete (with connection fitting and insect screen)</p>	<p>126850</p>

4.3 Notes on Potential Hazards

Safety valves protect pressurized areas from unacceptable excessive pressures. Accordingly, any change of setting or functional values, any replacement of seals or connections and any repair can only be performed by the manufacturer or authorized experts.

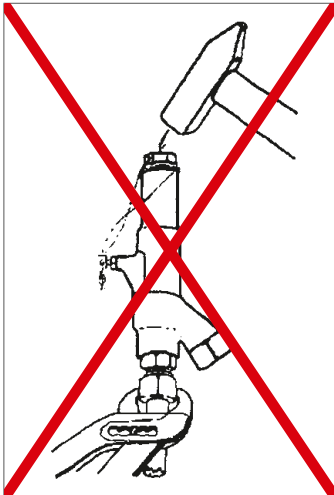
In addition, the use of the following materials and tools as well as the application of the following procedures (referring to MG-84 as an example) shall not be permissible:

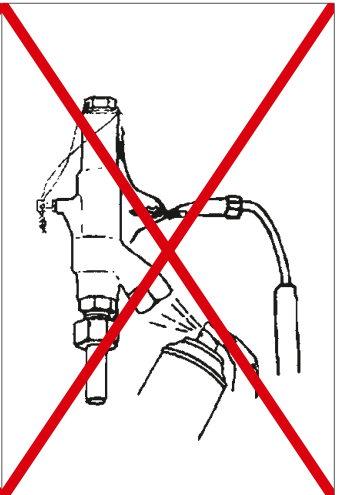
		
<ul style="list-style-type: none">• Tongs or pliers• Striking tools	<ul style="list-style-type: none">• Anti--seize spray• Sealants• Adhesives or sealing agents	<ul style="list-style-type: none">• Open fire• Splash water• Steam• Leakage detector spray• Suds

Approved and classified blow-off lines only (preferably with integrated protective strainer against insects) shall be fitted on the outlet side. No silencers shall be installed, since their back-pressure behaviour may reduce the blow-off efficiency of the safety valve to such an extent that a hazardous condition may result.



During discharge of the safety valves (opening pressure!) high acoustic pressures and high gas exhaust velocities will be encountered. Hazardous to your ears and eyes!

5 Maintenance and Service

5.1 Maintenance

The maintenance intervals must be determined by the operator according to the operating conditions based on a risk assessment. The recommendation for the functional check of the safety valves can be found in chapter 5.1.1 "Recommended inspection and maintenance intervals" of these operating instructions.

5.1.1 Recommended inspection and maintenance intervals

Recommended intervals		
Testing	Interval	Scope
Inspection	During commissioning	<ul style="list-style-type: none">• Visual inspection<ul style="list-style-type: none">- of the valve for damage- the legibility of the marking- the integrity of the seal• Leak tightness<ul style="list-style-type: none">- Screw connection of the valve seat• If present, actuation of the lifting
Test of function*	2-5 Years	<ul style="list-style-type: none">• If present, test of lifting including visual inspection.• Leakage test
Decommissioning	Every 10 years	<ul style="list-style-type: none">• Replacement with a new or reconditioned safety valve

*Specification of a time period, depending on the result of the risk assessment

5.1.2 Checks

Seat tightness and response pressures of safety valves may be checked by the bubble method outlined below. Incidents of contamination and corrosion of the valve mechanism will be greatly prevented.

The setting pressure is shown on the safety valve rating plate. Check intervals shall be a function of the specific environmental conditions existing at the place of installation and need to be defined by the operator!

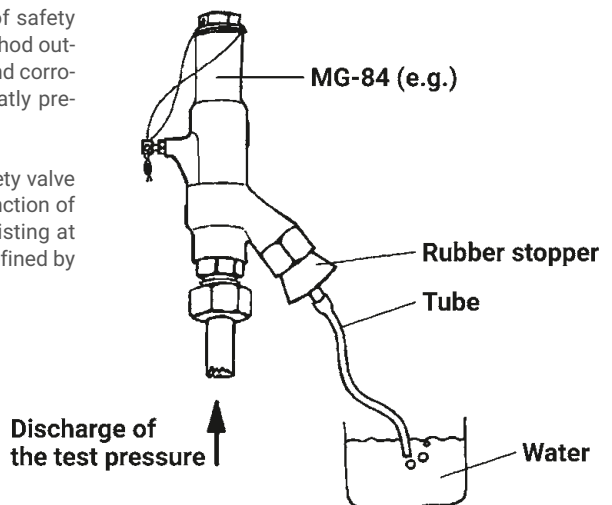

5.1.2.1 Application of test pressure

Use a suitable testing device for the purpose of the pressure test.

In the case of safety valves that are not to be dismantled, the feed pipe to the safety valve from the pressurized area of vessel must be shut off.



This must be reopened after testing. Make sure not to perform any checks or tests in the presence of oxygen or inflammable or corrosive gases.

5.1.2.2 Checking of seat tightness

Increase the test pressure to 90 % of the response pressure. The valve must remain tight, i.e. no bubbles shall be visible.

5.1.2.3 Checking of response pressure

Slowly increase the test pressure to 100 %. The response pressure will be indicated by an evident increase of bubbling.



Full-stroke safety valves will open abruptly! Under certain circumstances response pressure and opening pressure will be identical.

5.1.2.4 Checking of opening pressure

Remove rubber plug and slowly increase the test pressure. The opening pressure may be below or exceed the response pressure by up to 3 % and will occur with full stroke. This is mostly noted with a loud bang.

5.2 Repairs

Repairs are carried out exclusively by Air Liquide, with the appropriate original spare parts.

6 Dismantling and disposal

6.1 Notes regarding disassembly

Observe all national and local safety requirements. The piping system must be depressurized.

The medium and the safety valve must be at ambient temperature.

In the case of corrosive and aggressive media, vent / flush the piping system.

6.2 Disposal

1. Disassembly of Safety Valve

- Collect greases and lubricating fluids during disassembly.

2. Separate materials:

- Metals,
- Plastics.

3. Carry out sorted disposal.



The QR Code leads you to the online version of this manual.

Contact

Air Liquide Deutschland GmbH

Füttingsweg 34
47805 Krefeld
Tel: +49 (0) 2151 379 - 9444
equipment@airliquide.com
www.airliquide.de

Air Liquide Austria GmbH

Sendnergasse 30
2320 Schwechat
Tel: +43 810 242427
technik.at@airliquide.com
www.airliquide.at

Carbagas AG

Hofgut
3073 Gümligen
Tel: +41 31 95 05050
info@carbagas.ch
www.carbagas.ch

www.airliquide.de



A world leader in gases, technologies and services for Industry and Health, Air Liquide is present in 60 countries with approximately 66,300 employees and serves more than 3,9 million customers and patients.