

Pressure reducers for cylinders used with pure gases

User manual



1	Use	4
1.1	Intended use	4
1.2	Unintended use	4
1.3	ATEX Directive 2014/34/EC	4
1.4	REACH regulation (EC) n°1907/2006	4
1.5	PED Directive 2014/68/EC: Pressurized equipment	5
1.6	FOOD regulation (EC) n°1935/2004	5
1.7	Cleaning	5
2	Safety instructions	5
3	Starting operation	6
4	Stopping operation	8
5	Operation and maintenance note	9
5.1	Troubleshooting	9
5.2	Maintenance	9
5.3	Disposal	10
6	Repairs	10
7	Cylinder pressure regulators with flow meter gauge	10
8	Guarantee	10
9	Note	10
Appendix 1	Gas compatibility	11

DHP
 DHPS
 DIM
 DLM
 DLM-CO
 HBD
 HBD.S
 HD
 HDBS
 HD-CO

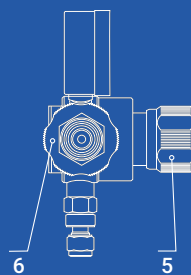
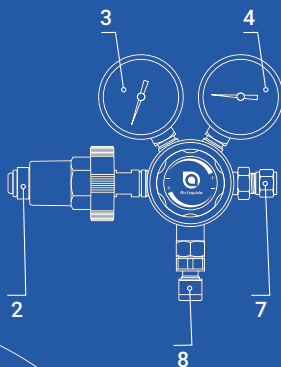
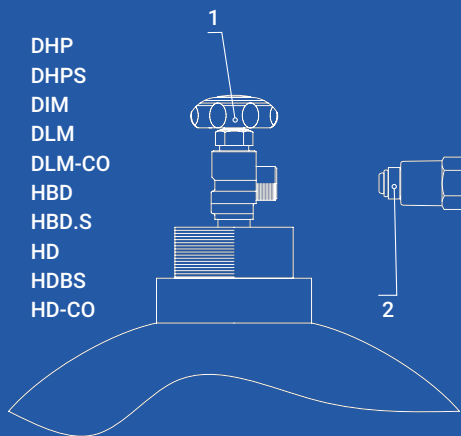

BSI-GLC 50
 Hepal 12 FOOD
 AHL

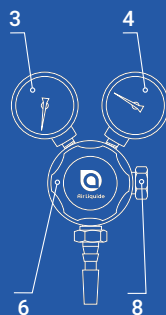
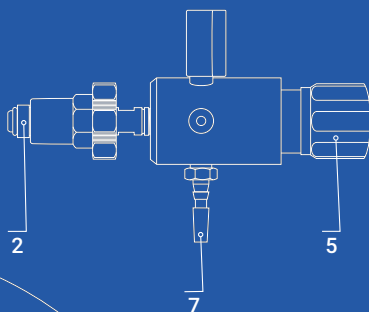
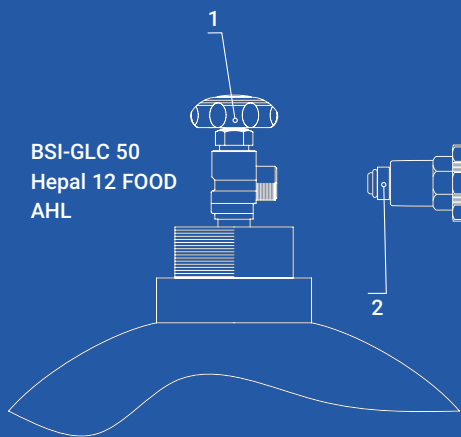

HBS
 HBSI

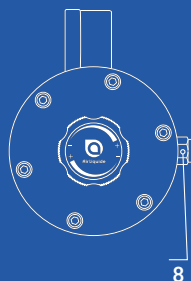
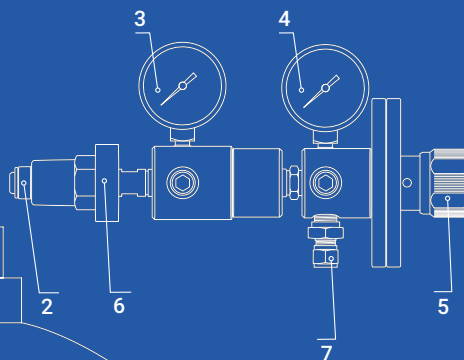
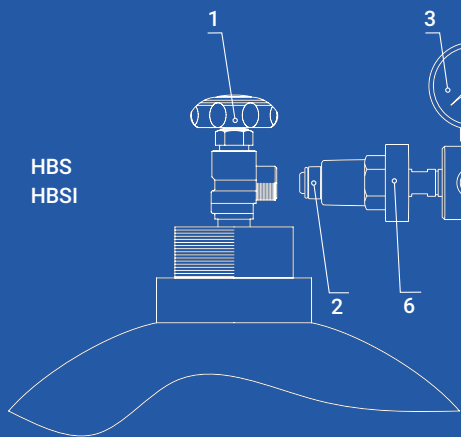

Description according to EN ISO 2503

1. Cylinder valve
 2. Inlet connection
 3. High pressure gauge
 4. Low pressure gauge
(gauge l/min in pressure regulator with flow-meter gauge)
 5. Pressure adjustment screw
 6. Shut-off valve
 7. Outlet connection
(E.g.. hose nozzle with filling nut.
Not included in the package.)
 8. Pressure relief valve
- On the regulator
- Date of production – Code
 - Manufacturer Code

This operating manual is intended to ensure the safe use of the pressure regulator for its intended purpose. Reading and following instruction in the operating manual contributes to prevent hazards, reduce downtime and increase reliability and service life of the devices.

THIS OPERATING MANUAL MUST ALWAYS REMAIN AVAILABLE WITHIN REACH.

For safety instructions see also Point 2: in case of doubt the manufacturer or distributor should be contacted.

1 Use

1.1 Intended use

These cylinder pressure regulators are intended for use with compressed gases released under pressure, on pressurized gas cylinders up to 300 bar filling pressure (depending on technical design) as well as for under pressure liquified gases, to reduce the corresponding cylinder pressure and to keep the desired working pressure constant. The pressure regulator must only be used for gases for which they've been designed for. See gas compatibility table in Appendix 1.

1.2 Unintended use

- Pressure regulation valves must not be used for liquids.
- Pressure regulators must not be operated in ambient temperatures below -20 °C and above 50 °C (see datasheet).
- Only use pressure reducers for the gases intended for them. These can be found in the gas compatibility table (see attachment 1) or in the corresponding product catalogue.

1.3 ATEX Directive 2014/34/EC

The cylinder pressure regulators are not in the scope defined in points a), b) et c) of the article of the ATEX Directive ; consequently, they shall not bear the CE marking.

The regulators are not capable of causing an explosion through their own potential sources of ignition: thus, they can be installed in ATEX zone 1 or 2, provided that up to date regulations, rules and operating instructions are observed accordingly during installation and operation.

Reminder: it is the responsibility of the end user to define the ATEX zone.

1.4 REACH regulation (EC) n° 1907/2006

The pressure reducers are made of brass parts, essentially the body, which is a copper alloy with a lead content between 1 % and 4 % w/w. As requested by art. 33 of REACH Regulation (Registration, Evaluation and Authorisation of Chemicals) and with reference to current list of SVHC (substances of very high concern) available on ECHA website, we inform that lead may be present in a concentration above 0,1 % in our products made of brass.

Lead inclusion in the SVHC list in June 2018 does not modify the use conditions described in operating instructions.

Lead will not be released to the surrounding environment or the gas used during normal use. After product end of life, the pressure reducers must be scrapped by an authorized metal recycler.

1.5 PED Directive 2014/68/EC: Pressurized equipment

The AIR LIQUIDE fittings with a nominal diameter <25 mm (e. g. pressure regulators, valves, filters, etc.) meet the requirements of Article 4, Paragraph 3 of the Directive 2014/68/EU and the provisions of the article. Therefore these devices do not bear a CE marking according to Article 18 of this Directive.

1.6 FOOD regulation (EC) n°1935/2004

The AL equipment enhancing the term "FOOD" in their designation are specifically designed for use with food gases used for food and beverage applications. They are compliant with Regulation EC 1935/2004 which requires that packaging and articles intended to be in contact with foodstuffs are to be manufactured in compliance with good manufacturing practices and standard operating procedures.

Thus, under normal or foreseeable conditions of use, no transfer of contaminants, eg, metal elements, to food in quantities that could endanger human health, modify food composition or deteriorate organoleptic characteristics is expected. Nevertheless, the end-user must check the compliance with an eventual national regulation.

Articles for food usage has a Food logo marking. For traceability purposes, the batch number is written on each article and AL can perform a batch recall, as requested by its Quality.

1.7 Cleaning

Each equipment is subject to a grease removal and a high quality cleaning to preserve the purity of gas in the equipment as well as for use with oxygen for compatible equipment.

A suitable packaging protects the equipment against exterior pollutants during storage and transport. Take care to avoid polluting the equipment during installation.

2 Safety instructions



All indications labeled with this symbol are considered as special safety instructions.

- 2.1 The pressure regulators conform to the recognized state of the art, as well as the requirements of existing standards.
 - No changes or alterations may be performed without the manufacturer's permission.
- 2.2 No adapters should be installed between the cylinder valve and the cylinder pressure regulator.



Improper operation, or use for purposes other than those intended can create hazards for the user and other persons, as well as damage to the pressure regulator.

In general, the regulations, standards and legal guidelines of the country of use are applied. As follows the most important from the D-A-CH region.

- 2.3 Regulations that are applicable in Germany:
 - 2.3.1 Accident prevention regulations / DGUV rules
 - 100-001 "Principles of prevention"
 - 113-001 "Explosion prevention rules" Name plate
 - 100-500 "Operation of work equipment"
 - 2.3.2 Laws, directives, technical regulations
 - Product safety law (ProdSG) with the specific:
 - Product safety directives (ProdSV), e.g. Explosion protection directive (11. ProdSV) or Pressure device directive (14. ProdSV)
 - 5. Dimensional drawing
 - Work safety directive with Appendix 1 – 3
 - Work safety technical rules (TRBS)
 - Hazardous materials technical rules (TRGS)
 - Plant safety technical rules (TRAS)
 - 2.3.3 Bulletins, norms and guidelines
 - Pressure equipment directive, 2014/68/EU
 - Bulletin Use of compressed gas cylinders (DVS 0212)
 - Refer to the safety data sheets of each specific gas type

2.4 Regulations that are applicable in Austria:

- Employee protection law ASchG
- Work equipment directive (AM-VO) BGBl. II. Nr. 164/2000 igF.
- General operating instructions for acetylene welding and cutting equipment according to § 26 para. 4 of the AM-VO.

2.5 Regulations that must be observed in Switzerland:

- SR 832.20 Federal Act on Accident Insurance (AIA)

Art. 82 The employer is obligated to take all the necessary steps to prevent workplace accidents and occupational diseases, which, according to experience, are necessary, can be applied according to the latest technology and are appropriate for the respective circumstances.

- SR 832.30 Ordinance on the Prevention of Art. 3
- SR 930.114 Ordinance on the Safety of Pressure Equipment (Pressure Equipment Regulation, DGV)
- SR 832.312.12 Ordinance on the Safety and Health Protection of Workers in the Use of Pressure Equipment (Use of Pressure Equipment Ordinance, DGVV)
- PrSG = Bundesgesetz über die Produktesicherheit SR 930.11
 - Verordnung über die Produktesicherheit PrSV SR 930.111
 - Verordnung über die Sicherheit von Maschinen SR 819.14

2.6 Safety instructions for toxic and corrosive gases:

- Due to malfunctions or open safety devices, harmful gases and vapors can may escape. Ensure sufficient ventilation or exhaust ventilation. In case of hazardous gases, take special actions. In particular, connect the outlets of the safety valve and purge valves with fixed pipelines and dispose the substances in a safe and environmentally compatible manner.
- When changing cylinders with toxic, flammable or corrosive gases, appropriate personal protection measures must be taken. The permissible values of the workplace concentration must be observed.

- Operators must be made aware of the special hazards of the gas and of possible personal and that other protective measures are pointed out.

Toxic and corrosive gases:

- Risk of poisoning and chemical burns!

Flammable gases:

- Fire and explosion hazard!

Oxidizing gases:

- Strongly fire-promoting!

Inert gases:

- Risk of suffocation!

3 Starting operation

The sequence must be strictly respected!



Explosion hazard! All parts such as tools and hands that come into contact with oxygen must be kept free from oil and grease.

- 3.1 Before starting work, the instructions in this operating manual must be read and followed during the work!
- 3.2 Check if the pressure regulator is suitable for the intended gas type and pressure (see symbol Point 3).
- 3.3 Before using the pressurized equipment make sure that no one can be injured or endangered by starting up the the pressurized unit.
- 3.4 Check if the cylinder valve connector and the seal are clean and undamaged. In case of any damage, the pressure regulator must not be connected.



Before connecting the regulator, briefly open the cylinder valve once and close it again to blow out any dirt particles that may be present. Do not stand in front of the outlet of the valve and make sure that there is no danger from the escaping gas. Ensure good ventilation. Do not blow out flammable, corrosive, toxic or irritant gases.

- 3.5 Connect the regulator with screw connection to the bottle valve (1) using a suitable spanner or connection bracket (2) in a gas-tight manner. For regulators with manual connection (O-ring seal), this screw connection must be tightened by hand. No tools must be used for manual connection. The

mounting position of the regulator must always be vertical to the pressure gauges.

- 3.6 Mount a suitable compression fitting/hose nozzle on the outlet of the regulators and seal it using a suitable wrench.



- 3.7 Connect the hose nozzle to the outlet connection (7) and to the consumer device. Link the hoses and hose connections (hose nozzles) according to the current standard. Secure hoses with suitable hose clamps.

1. The clamped metal tubes must always be softer than the material of the double ferrule fittings. For example, stainless steel tubes must never be used with brass tube fittings.
2. Support sleeves are always necessary for soft or flexible tubes. They give the hose the strength it needs for a leak-free seal.
3. Make sure that the tube is cut perpendicular (a good quality tube cutter with a suitable cutting edge is recommended) and deburred. There must be no chamfer at the end of the pipe.
4. Insert the tube inside the connector up to the stop limit on the body. Clamp the nut completely by hand (Fig. 1).

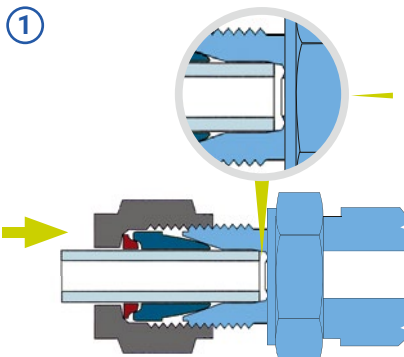

5. Hold the fitting body firmly and mark the position of the union nut. Complete the clamping using a wrench by turning the nut a 1 1/4 turn (Fig. 2). The connection is now correctly mounted.

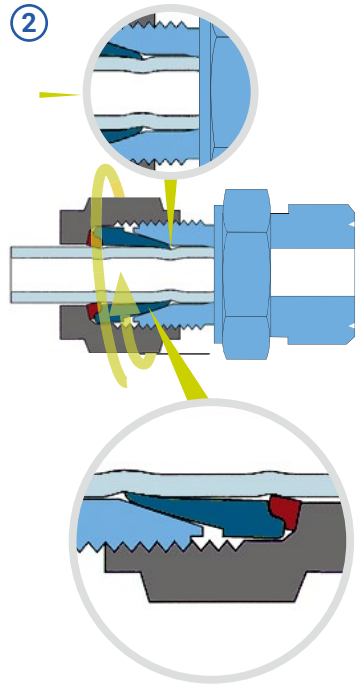

6. For screw connections up to 4 mm, only one 3/4 turn from the hand-tight position is permissible.

3.8 Instructions for reassembly

Connections can be loosened and retightened several times while maintaining a reliable, leak-free seal.

1. Before loosening the connection, mark the position of the nut to the fitting body.
2. Push the pipe with pre-assembled clamping rings into the body until the pre clamping ring is firmly seated.
3. Tighten the union nut by hand. Then tighten the union with the spanner until you reach the old assembled state position. If you reach this position, you will notice an increased resistance when tightening. Then tighten the union nut lightly with the open-ended spanner. Smaller pipes require less tightening than large ones.

3.9 Adjusting the pressure

Before releasing the gas into the system, check the following:

1. Correct version of the cylinder pressure regulator
2. All indicators at zero
3. Pressure fully turned off on the pressure adjustment screw (5) (anticlockwise)
4. Re-adjustment valves are closed.

Then close the shut-off valve (6) and release pressure and pressure regulator by unscrewing the pressure adjustment screw (5). Open the cylinder valve slowly, the high-pressure gauge (3) indicates the cylinder pressure. Open the shut-off valve (6) and slightly open the corresponding shut-off valve of the consumer device. Then screw down the pressure adjustment screw (5) to set the desired outlet pressure (operating pressure) and check it on the low pressure gauge (4). Correct the pressure setting if the pressure dips.



Perform leak test. Never use leaking or defective devices. Never point an open flame to leaking device. Never tighten leaking screw connections which are under pressure.

4 Stopping operation

- For short shutdown periods: close the shut-off valve on the pressure regulator.
- For longer shutdown periods: Close the cylinder valve, release pressure, pressure regulator has zero pressure, loosen pressure adjustment screw (5). Close the shut-off valves on the pressure regulator and the consumer device. Never tighten or loosen screw connectors while they are under pressure!

5 Operation and maintenance note

5.1 Troubleshooting

Default	Cause	Remedy
Mounting impossible	Connections cannot be mount	Verify the compatibility of gases, inlet and outlet
	Damaged connections	Replace the regulator
Insufficient flow rate	Cross section of passage limited by a valve	Open the valve
	Insufficiently filled or empty cylinder	Change the cylinder
	Valve not operating	Change the cylinder
	Under-dimensional equipment	Contact Air Liquide
	Downstream device not operational	Change the device
Gas leak	Tightness default	Close the cylinder valve and replace the safety valve.
Gas comes out of the relief valve	Leakage at the poppet or damaged relief valve	
Rise of the outlet pressure	Leakage at the poppet	
Unstable outlet pressure or frosting	Working temperature too low	Close the cylinder valve. Bring back the equipment temperature above 0 °C.
	Gas used is (Ar), carbon dioxide (CO ₂) or nitrous oxide (N ₂ O).	Use a heater at the inlet.
	Flow rate to high	Respect the max. flow rate of the regulator. Limit the flow by a valve or a calibrated orifice.
Vibrations	Flow rate to high	Limit the flow by a valve or a calibrated orifice.
	Presence of valve with quick opening on the downstream pipe	

5.2 Maintenance

Always protect the pressure regulator from damage (visual inspection at regular intervals).

 **The factory settings of the connection seals must not be changed.**

Ensure that the connector seals, sealing surfaces and gauges are in perfect condition.

 **If a fault occurs, for example if the outlet pressure rises when output = 0, if there are leaks into the atmosphere, the gauges are defective, or when the safety valve is activated, shut off the pressure regulator, close the cylinder valve immediately.**

Air Liquide recommends annual periodic inspections of the pressure regulator by competent, authorized personnel. The frequency of this test depends mainly on the use of the device (intensive, moderate, occasional).

 **Faults that occur can have many causes. For your own safety, avoid tampering or making repairs on your own.**

5.3 Disposal and recycling

At the end of the equipment's useful life or when it is impossible to repair it, it is essential to respect the local regulations for recycling / disposal of our equipment. To prevent reuse, these products must be unsuitable for use.

In accordance with EU Directive 2018/851 on waste, the owner of the equipment ensures that when recovery is not carried out in accordance with article 10, the waste will be subjected to safe disposal operations that comply with the provisions of article 13 on the protection of human health and the environment.

The licensee must take steps to promote high quality recycling and, to this end, must establish separate waste collections when technically, environmentally and economically feasible and adequate to meet the quality standards required by the relevant recycling sectors.



6 Repairs



Repairs to the pressure regulators must only be done by competent and trained personnel in authorized specialist workshops. Only original spare parts must be used for repairs.

- 6.1 If unauthorized repairs or changes are made by the user or a third party without permission from the manufacturer, responsibility will no longer be assumed for the consequences.

7 Cylinder pressure regulators with flow meter gauge

For these pressure regulators, points 1 to 7 in this operating manual also apply. The flow quantity set by the pressure adjustment screw (5) is indicated on the flow meter gauge (4). In pressure regulators with a flow meter gauge, a regulating office/throttle (for pressure control) (9) is built in. Check if a regulating office/ throttle (for pressure control) is already installed in your equipment. If yes this must be removed because the mounting holes are not adapted to the pressure regulator.

8 Guarantee

The standard warranty period is one year from the date of delivery in accordance with the general terms and conditions of Air Liquide. The standard warranty period is only valid for goods that have been used according to the operating manual and generally applicable industry practices and standards.

9 Note

Please use the product only for the purpose that Air Liquide intended and only if you are competent in the application and follow the technical safety guidelines or safety procedures. If there are any doubts related to the use of the product, request specific Air Liquide product information beforehand or talk to an Air Liquide specialist.

Appendix 1: Gas compatibility

Equipment	Parameters			Main gases															
	Number of pressure stages	Max. flow rate in Nm ³ /h	Adjustable Back pressures minimum to maximum in bar	Ammonia	Methane	Ethylene	Propylene	Propane	Acetylen	Hydrogen	Nitrous oxide	Oxygen	Synth. air	Breathable air	Carbon monoxide	Carbon dioxide	Argon-CO ₂ -mixture	Inert gases	
Chromed-brass HP Reducers																			
AHL	1	25	1.0 - 16	▲	▲	▲	▲	▲	▲	200	44	200	200	▲	▲	50	200	200	
Hepal 12 FOOD	1	25	1.0 - 16	▲	▲	▲	▲	▲	▲	200	▲	200	200	▲	▲	50	200	200	
HD 300	1	8	0.3 - 16	▲	▲	▲	▲	▲	▲	300	44	300	300	▲	▲	50	300	300	
HD 300 CO	1	2	1.0 - 4	▲	▲	▲	▲	▲	▲	▲	200	▲	▲	▲	▲	▲	▲	▲	
HBS; HBS.V	2	3.5	0.01 - 10	▲	▲	▲	▲	▲	▲	200	44	200	200	▲	▲	50	200	200	
HDBS	2	5	0.1 - 10	▲	▲	▲	▲	▲	▲	300	44	300	300	▲	▲	50	300	300	
DLM 300; DLM BA	1	100	0.5 - 50	▲	▲	▲	▲	▲	▲	200	44	300	200	▲	▲	50	300	300	
DLM 200 CO	1	8	1.0 - 15	▲	▲	▲	▲	▲	▲	▲	200	▲	▲	▲	▲	▲	▲	▲	
DLS	1	12	0,1 - 15	▲	▲	▲	▲	▲	▲	200	44	200	200	▲	▲	50	200	200	
DHP 200	1	30	20 - 200	▲	▲	▲	▲	▲	▲	200	44	200	200	▲	▲	▲	200	200	
DHPS 200	1	30	20 - 200	▲	▲	▲	▲	▲	▲	200	▲	200	200	▲	▲	▲	200	200	
Stainless steel HP Reducers																			
DIM	1	50	1.0 - 25	▲	▲	70	▲	▲	▲	200	▲	200	200	▲	▲	▲	200	200	
HD.S	1	5	0.2 - 8	▲	▲	70	▲	▲	▲	200	▲	200	200	▲	▲	▲	200	200	
HBD.S	2	5	0.2 - 8	▲	▲	70	▲	▲	▲	200	▲	200	200	▲	▲	▲	200	200	
HBSI	2	3.5	0.05 - 10	▲	▲	▲	▲	▲	▲	200	44	200	200	▲	▲	200	200	200	
BSI-GLC 50	1	3.5	0.05 - 10	▲	▲	▲	▲	▲	▲	▲	50	▲	▲	▲	▲	▲	▲	▲	

Contact

Air Liquide Deutschland GmbH

Fütingsweg 34
47805 Krefeld
Tel: +49 (0) 2151 379 - 4555
equipment@airliquide.com
www.airliquide.de

Air Liquide Austria GmbH

Sendnergasse 30
2320 Schwechat
Tel: +43 810 242427
technik.at@airliquide.com
www.airliquide.at

Carbagas AG

Hofgut
3073 Gümligen
Tel: +41 31 95 05050
info@carbagas.ch
www.carbagas.ch

Air Liquide Romania SRL

Dinu Vintila street, no.11
Euro Tower building, 7th floor
Bucharest, District 2, 021101
Tel: +40-21-311.96.80/81/82/83/84
office.romania@airliquide.com
www.airliquide.ro

Air Liquide Polska Sp. z o.o

ul. Jasnogórska 9
31-358 Kraków
Tel: +48 12 627 93 00
instalacje.pl@airliquide.com
przemysl.air-liquide.pl

Air Liquide Bulgaria

Hofgut
1 Business Park Sofia Street Build. 7B
Floor 5
1766 Sofia
Tel: +359 2 489 9782

Air Liquide Gaz San. ve Tic. AŞ

Resitpasa Mah. Eski Büyükdere Cad.
Park Plaza No:14 Kat:2 D:8
34398 Maslak
Sarıyer - Istanbul
Tel: +90 212 345 11 40
ww-musteri-hizmetleri@airliquide.com
tr.airliquide.com



A world leader in gases, technologies and services for Industry and Health, Air Liquide is present in 78 countries with approximately 64,500 employees and serves more than 3.8 million customers and patients.